



Usable even in hazardous atmospheres with hydrogen and acetylene present!

HART communication compatible

Intelligent Gas Detector

Detection target gases	Model
Combustible gases	SD-1
	SD-1RI
Combustible gases/Toxic gases	SD-1GH
Carbon monoxide/hydrogen sulfide	SD-1EC
Oxygen	SD-1OX

SD-1 Series

- ATEX
- IECEX
- TIIS (Japan Ex)
- MED
- SIL2



Extensive lineup of models for any location!



Oil refineries, plants producing basic petrochemical products



Service and utility tunnels, construction sites



Shipping and offshore facilities



RIKEN KEIKI Co., Ltd.

Example of connection with indicator/alarm unit (e.g., RM-5000 series) and alarm monitoring system

Create a secure workplace with a comprehensive system

The SD-1 series is a compact lightweight Intelligent Gas Detector ideal for deployment in refineries and petrochemical plants. The series includes an extensive lineup of models for detecting combustible gases, toxic gases (hydrogen sulfide/carbon monoxide), and oxygen. These devices also offer various functions and features, including HART communication and SIL2 certification. The rugged chassis and range of accessories makes this series ideal for the harshest environments. Connecting this product to indicator/alarm units at local safety points and upstream systems in centralized monitoring rooms or metering rooms helps establish comprehensive disaster prevention systems.

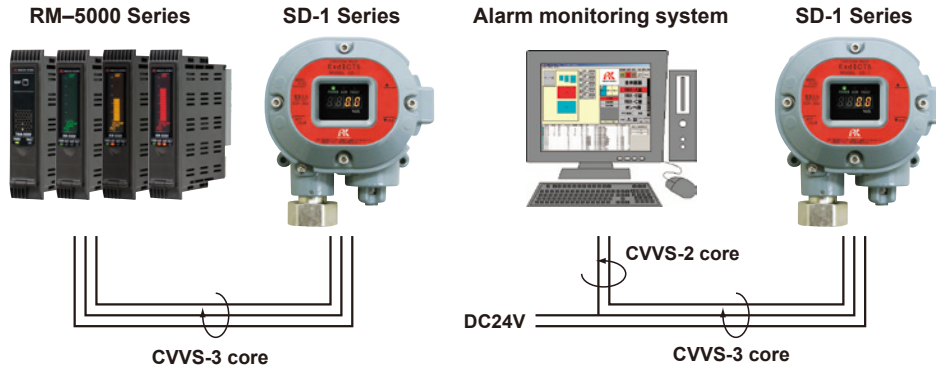

Lineup

For combustible gases



For combustible gases/toxic gases



Specifications

Model	SD-1		SD-1RI
	TYPE GP	TYPE NC	—
Detection principle	Catalytic combustion type	New ceramic type	Non-dispersive infrared type
Detection target gas	Combustible gas		
Detection method	Diffusion type		
Detection range	0–100 % LEL	Depends on detection target gas.	0–100 % LEL
Alarm setpoints	25 % LEL (standard)	Depends on detection target gas.	25 % LEL (standard)
Alarm accuracy (for identical conditions)	Within ± 25 % of alarm setpoint		
Alarm delay (for identical conditions)	Within 30 seconds after gas reaches 1.6 times the alarm setpoint		
Alarm indications	Gas alarm: ALM LED lights up (red). Fault alarm: FAULT LED lights up (yellow)/information displayed.		
Transmission specifications ^{*1}	3-wire analog transmission 4–20 mA DC (common cable for power and signal [power, signal, common])		
Gas concentration display	4-digit 7-segment LED		
Explosion-proof	Flame-proof enclosure		
Explosion-proof class ^{*2}	Japan Ex	Ex d IIC T5 X	Japan Ex Ex d IIC T6 X
	ATEX	II 2G Ex db IIC T5 Gb IECEX Ex db IIC T5 Gb	ATEX II 2G Ex db IIC T6 Gb IECEX Ex db IIC T6 Gb
Protection level	P65 equivalent		
Operating temperature/humidity range	Japan Ex -20°C – +53°C (no sudden changes), up to 95 % RH (no condensation) ATEX/IECEX -20°C – +60°C (no sudden changes), up to 95 % RH (no condensation)		
Power source	24 V DC ± 10 %		
Power consumption	Max. 3 W	Max. 3 W	Max. 2 W
External dimensions	Approx. 148 mm (W) \times 167 mm (H) \times 88 mm (D) (excluding projections)		
Weight	Approx. 2.0 kg		

*1 Specify HART communication specification requirements when ordering.

*2 Specify explosion-proof specification requirements when ordering.

Specifications

Model	SD-1GH	
Detection principle	Semiconductor type	
Detection target gas	For combustible gases/toxic gases	
Detection method	Diffusion type	
Detection range	Depends on detection target gas.	
Alarm setpoints	Depends on detection target gas.	
Alarm accuracy (for identical conditions)	Within ± 25 % of alarm setpoint (combustible gases) Within ± 30 % of alarm setpoint (toxic gases)	
Alarm delay (for identical conditions)	Within 30 or 60 seconds (depending on detection target gas) after gas reaches 1.6 times the alarm setpoint	
Alarm indications	Gas alarm: ALM LED lights up (red). Fault alarm: FAULT LED lights up (yellow)/information displayed.	
Transmission specifications ^{*1}	3-wire analog transmission 4–20 mA DC (common cable for power and signal [power, signal, common])	
Gas concentration display	4-digit 7-segment LED	
Explosion-proof	Flame-proof enclosure	
Explosion-proof class ^{*2}	Japan Ex	Ex d IIC T5 X
	ATEX	II 2G Ex db IIC T5 Gb IECEX Ex db IIC T5 Gb
Protection level	IP65 equivalent	
Operating temperature/humidity range	Japan Ex -20°C – +53°C (no sudden changes), up to 95 % RH (no condensation) ATEX/IECEX -20°C – +60°C (no sudden changes), up to 95 % RH (no condensation)	
Power source	24 V DC ± 10 %	
Power consumption	Max. 3.1 W	
External dimensions	Approx. 148 mm (W) \times 167 mm (H) \times 88 mm (D) (excluding projections)	
Weight	Approx. 2.0 kg	

*1 Specify HART communication specification requirements when ordering.

*2 Specify explosion-proof specification requirements when ordering.

Functions

》》》 Explosion-proof in hydrogen/acetylene environments

Flame-proof enclosures enable use as an explosion-proof product in hydrogen/acetylene environments.

》》》 Waterproof/Dust-proof

Protection rating equivalent to IP65. Suitable for use in harsh environments.

》》》 Compatible with HART communications

The product sends digital signals across general analog 4 - 20 mA output lines to allow data exchange over a broad range.

》》》 Equipped with self-diagnostic function

The device performs self-diagnostics after power supply starts.

In the event of an error, instead of displaying the gas concentration, the product will display a fault description (error code) pointing to a potential cause of the problem.

》》》 Supports gas detection by aspiration

Connecting the SD-1 Series suction cap (with gas flow inlet/outlet) to the product sensor allows gas detection by aspiration.

* Use for gas detection by aspiration requires a suction pump and aspirator unit (available separately), in addition to a power supply.

For hydrogen sulfide/carbon monoxide



For oxygen



》》》 Specifications

Model	SD-1EC
Detection principle	Electrochemical type
Detection target gas	Hydrogen sulfide/carbon monoxide
Detection method	Diffusion type
Detection range	Hydrogen sulfide: 0–30 ppm Carbon monoxide: 0–75 ppm
Alarm setpoints	Depends on detection target gas.
Alarm accuracy (for identical conditions)	Within ± 30 % of alarm setpoint
Alarm delay (for identical conditions)	Within 30 seconds after gas reaches 1.6 times the alarm setpoint
Alarm indications	Gas alarm: ALM LED lights up (red). Fault alarm: FAULT LED lights up (yellow)/information displayed.
Transmission specifications ^{*1}	3-wire analog transmission 4–20 mA DC (common cable for power and signal [power, signal, common])
Gas concentration display	4-digit 7-segment LED
Explosion-proof	Flame-proof enclosure
Explosion-proof class ^{*2}	Japan Ex Ex d IIC T6 X
	ATEX II 2G Ex db IIC T6 Gb
	IECEX Ex db IIC T6 Gb
Protection level	P65 equivalent
Operating temperature/humidity range	-10°C – +40°C (no sudden changes), up to 30 – 80 % RH (no condensation)
Power source	24 V DC \pm 10%
Power consumption	Max. 1.1 W
External dimensions	Approx. 148 mm (W) \times 203 mm (H) \times 88 mm (D) (excluding projections)
Weight	Approx. 2.2 kg

^{*1} Specify HART communication specification requirements when ordering.

^{*2} Specify explosion-proof specification requirements when ordering.

》》》 Specifications

Model	SD-1OX
Detection principle	Galvanic cell type
Detection target gas	Oxygen
Detection method	Diffusion type
Detection range	0–25.0 vol%
Alarm setpoints	18.0 vol%
Alarm accuracy (for identical conditions)	The difference between the alarm setpoint and the concentration reading when the alarm is triggered is 0.
Alarm delay (for identical conditions)	Within five seconds after detecting a 10 to 11 vol% gas for oxygen deficiency alarm
Alarm indications	Gas alarm: ALM LED lights up (red). Fault alarm: FAULT LED lights up (yellow)/information displayed.
Transmission specifications ^{*1}	3-wire analog transmission 4–20 mA DC (common cable for power and signal [power, signal, common])
Gas concentration display	4-digit 7-segment LED
Explosion-proof	Flame-proof enclosure
Explosion-proof class ^{*2}	Japan Ex Ex d IIC T6 X
	ATEX II 2G Ex db IIC T6 Gb
	IECEX Ex db IIC T6 Gb
Protection level	IP65 equivalent
Operating temperature/humidity range	-10°C – +40°C (no sudden changes), up to 95 % RH (no condensation)
Power source	24 V DC \pm 10%
Power consumption	Max. 1.1 W
External dimensions	Approx. 148 mm (W) \times 208 mm (H) \times 88 mm (D) (excluding projections)
Weight	Approx. 2.5 kg

^{*1} Specify HART communication specification requirements when ordering.

^{*2} Specify explosion-proof specification requirements when ordering.

SIL2-certified for all aspects of the functional safety standard—a first for Japanese manufacturers

The growing importance of safety within the processing industry has generated demand for devices certified to be compliant with the IEC 61508 functional safety standard. Functional safety certification seeks to promote the development of safe systems with lower risks by dividing system safety into levels based on the likelihood of faults that would lead to system stoppages.

With the SD-1 series, Riken Keiki becomes the first manufacturer of gas detectors in Japan to be certified to comply with SIL2 levels in all aspects of the IEC 61508:2010 functional safety certification.

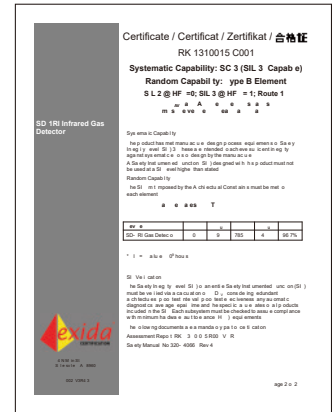

Explosion-proof/Certifications/Functionality

Model		SD-1				SD-1RI		SD-1GH		SD-1EC		SD-10X			
Type		TYPE GP	TYPE GP H	TYPE NC	TYPE NC H	—	TYPE H	TYPE HS	—	TYPE H	—	TYPE H	TYPE HS		
Explosion-proof	Explosion-proof construction	Flame-proof enclosure													
	Japan Ex	Ex d IIC T5 X				—		Ex d IIC T6 X		Ex d IIC T5 X		Ex d IIC T6 X		Ex d IIC T6 X	
	ATEX	II 2G Ex db IIC T5 Gb				—		II 2G Ex db IIC T6 Gb		II 2G Ex db IIC T5 Gb		II 2G Ex db IIC T6 Gb		II 2G Ex db IIC T6 Gb	
	ECEX	Ex db IIC T5 Gb				—		Ex db IIC T6 Gb		Ex db IIC T5 Gb		Ex db IIC T6 Gb		Ex db IIC T6 Gb	
Certifications	CE marking	Compliant													
	MED*1	○	—	—	—	—	—	*2	—	—	—	—	—	*2	
	S L	—	—	—	—	—	—	S L 2	—	—	—	S L 2	—	—	SIL2
Communication functionality	HART communication	—	HART 7	—	HART 7	—	HART 7	—	HART 7	—	HART 7	—	HART 7		

*1 Depends on gas type.

*2 MED-compliant models are also available. (4 - 20 mA, no contact)

Optional accessories (sold separately)

Model		SD-1	SD-1RI	SD-1GH	SD-1EC	SD-10X	Applications
Optional accessories (sold separately)	Sunshade (for mounting on wall or pipe)	○	○	○	○	○	This cover minimizes rising temperatures in the main unit due to exposure to direct sunlight or radiant heat.
	Protective cover (for mounting on wall or pipe)	○	○	○	○	○	Cover for protecting main unit
	Display cover	○	○	○	○	○	Sunshade for the display section
	Calibration adapter	○	○	○	○	○	Calibration adapter
	Solvent protection cover	○	○	○	○	○	Solvent protection cover for the display section.
	U-bolt unit	○	○	○	○	○	Kit for mounting main unit to 2B pole
Round splash-proof cap	○	○	○	—	—	Splash-proof cover for the sensor section.	

★ Distributed by:



* The contents described in this catalog are subject to change without notice according to the performance improvement.